

# Overflow Regulator Type 86



*Image: 1 - Overflow regulator  
Type 86*



## Overflow Regulator Type 86

### Task

The Type 86 overflow regulator always ensures that suction pressure does not drop, that means it opens when suction pressure drops below a specified level during the start-up of the open suction system in order to protect excess strain on upstream containers or compressors.

Due to the existing low-pressure conditions ( $p < 0.5$  bar (ü)) the Type 86 overflow regulator is not subject to the application of Pressure Equipment Directive **97/23/EC**, but naturally it is designed and manufactured in compliance with applicable engineering practices.

*Consequently, the Type 86 equipment may fundamentally, with regard to the documentation, not be furnished with a declaration of conformity!*

### Features

- Connections tailor-made to customer specifications (also ANSI and special flanges).
- Structural height well-adaptable to onsite conditions.
- Pressure-compensated valve-setting mechanism by use of a compensation diaphragm
- High regulating accuracy, short response time, and also low pressure differences can be regulated.
- Service-friendly, onsite maintenance with disassembly of the device is possible, no special tools needed.
- Simple construction, few parts subject to wear.
- Special model type H up to 250°C operating temperature possible.
- Not dependent on external energy.
- Assembly of the differential pressure pipe and presetting of the switch points take place in the factory.
- Compliance with the noise emission requirements of the setup area by means of optional soundproofing versions.
- No-load start-up possible with optional equipping with electromagnetic valve.

### Technical data

<b>Inlet pressure</b>	Atmospheric pressure
<b>Min. pressure difference</b>	100 mbar; 20 mbar with enlarged operating diaphragm
<b>Nominal width</b>	DN 80 – 300 (others on request)
<b>Connection type</b>	DIN, ANSI and special flange
<b>Valve diameter</b>	50 mm to 200 mm
<b>Operating temperature</b>	-15°C to +130°C; 250°C (H model type)
<b>Medium</b>	Air, if needed other gases on request
<b>Materials</b>	
Body	Steel/high-grade steel
Diaphragm casing	Cast steel/steel
Control regulator	Aluminium/high-grade steel
Inner parts	High-grade steel
Diaphragms, o-rings	Perbunan, Viton
Cone valve	Perbunan, Viton
<b>Soundproofing (optional)</b>	Firstly at the valve, reduction of approx. 5 dB(A)
	Secondary (coaxial to filter element), reduction of approx. 10 dB(A)

### Adjustment Ranges

Guide range [bar]	Drawing number	RG	SG
<b>Control regulator DUH</b>			
0.05 – 0.30	4-St-12/DH/4	2.5	5
0.30 – 1.00	4-St-12/DH/5	2.5	5
1.00 – 1.90	4-St-12/DH/6	2.5	5
1.90 – 2.90	4-St-12/DH/7	1	2.5
2.90 – 4.30	4-St-12/DH/8	1	2.5
4.30 – 7.50	4-St-12/DH/9	1	2.5

Other set pressure ranges on request!



## **Function** (see Illustration 1.1)

If a compressor is started up in a plant, a certain low pressure = operating suction pressure is reached in the upstream network, to which the **ÜSR 86** is usually connected via a nipple **15**. The bottom diaphragm chamber (compensation diaphragm **3** at the top or operating diaphragm **4** at the bottom) is now equally pressurised with this operating suction pressure through a vertical and horizontal drill hole in the hollow spindle **2**. At the same time a low-pressure equalisation takes place via the control nozzle **5**, so that the operating suction pressure is finally also present in the top diaphragm chamber (operating diaphragm **4** at the top).

The operating suction pressure consistently operates on the control diaphragm **7** of the control regulator **18** via the control line **6**. If the operating suction pressure increases to an unacceptable level, which is determined via the setting of the spring **8**, the control valve **9** opens and via the pipeline **10** ensures that atmospheric pressure exists in the top chamber after a short period of time. The pressure difference that is created on the operating diaphragm **4** in this way – against the closing force of the spring **17** – opens the cone valve **11**.

The adjustment takes place on the adjustment knob **11** of the regulator. Turning it to the right reduces the absolute pressure by strengthening the force of the spring.

The suction pressure is very precisely regulated via a control regulator of Type DUH with only very little deviations with the favourable regulation group of 1 – 2.5.

**Right turn = low pressure increase**

## **Initial operation**

### **Warning!**

The suction line must be completely without pressure during installation – risk of injury!

The Type 86 regulator is supplied ready for operation. The installation position can be randomly chosen. However, the control regulator must always be installed vertically, in other words, independent from the final installation position.

In order to take a test pulse from a calm-flow zone, the pulse line **6** must be connected to the pressure line approximately 3 to 5 x D<sub>Connection Pipe</sub>, whereby

the opening in the bottom diaphragm casing must be closed.

### **Warning!**

The intake opening (complete lateral surface) of the filter must be protected against materials that can block it at all costs!

## **Maintenance instructions**

(See Illustration 1.1/2 or Parts List 1.1/2)

### **Warning!**

The overflow regulator should only be installed or serviced and repaired by expert technical staff. The overflow regulator must be operated and repaired in compliance with all applicable international standards and regulations and according to manual supplied by R + A Terschüren GmbH.

### **Suction filter replacement**

In the scope of the maintenance regularly performed by R + A, the filter is examined and replaced if necessary.

**Electromagnetic valve:** the operating manual, being part of the delivery of the Type 86, of the optionally installed electromagnetic valve must be adhered to.

### **Potential malfunctions:**

- Regulator does not close:

*Cause: Control nozzle **5** blocked, (optional) electromagnetic valve or control regulator valve leaking*

- Regulator leaking:

*Cause: Valve seal destroyed, foreign object between cone valve **1** and valve seat*

- Regulator does not open:

*Cause: Operating diaphragm **4** leaking*

## Components for the Type 86 Actuator

x1	1	Piece	Cone valve	4-132-13/	St, Perbunan / Viton
2	1	Piece	Hollow spindle	-	St / VA
x3	1	Piece	Compensation diaphragm	-	Perbunan / Viton
x4	1	Piece	Operating diaphragm	4-132-3/	Perbunan / Viton
5	1	Piece	Control nozzle	4-132-5 / 4-94-5	VA
6	1	Piece	Control line	-	St, galvanised
7	1	Piece	Control diaphragm	see p. 5, Item x 8	
8	1	Piece	Set-point spring	see p. 5, Item 12	
9	1	Piece	Control valve	see p. 5, Item x 1	
10	1	Piece	Control line	-	St, galvanised
11	1	Piece	Hand knob	-	St, PET
12	1	Piece	Vertical column	-	St
13	1	Piece	Self-locking hexagonal nut	DIN 985	St, galvanised
<b>Item</b>	<b>Quantit y</b>	<b>Unit</b>	<b>Description</b>	<b>Standard / drawing number</b>	<b>Material / Comment</b>

Parts List 1.1 – x: Keep consumables or parts subject to wear in stock

Illustration 1.1 – Type 86, maintenance-related parts

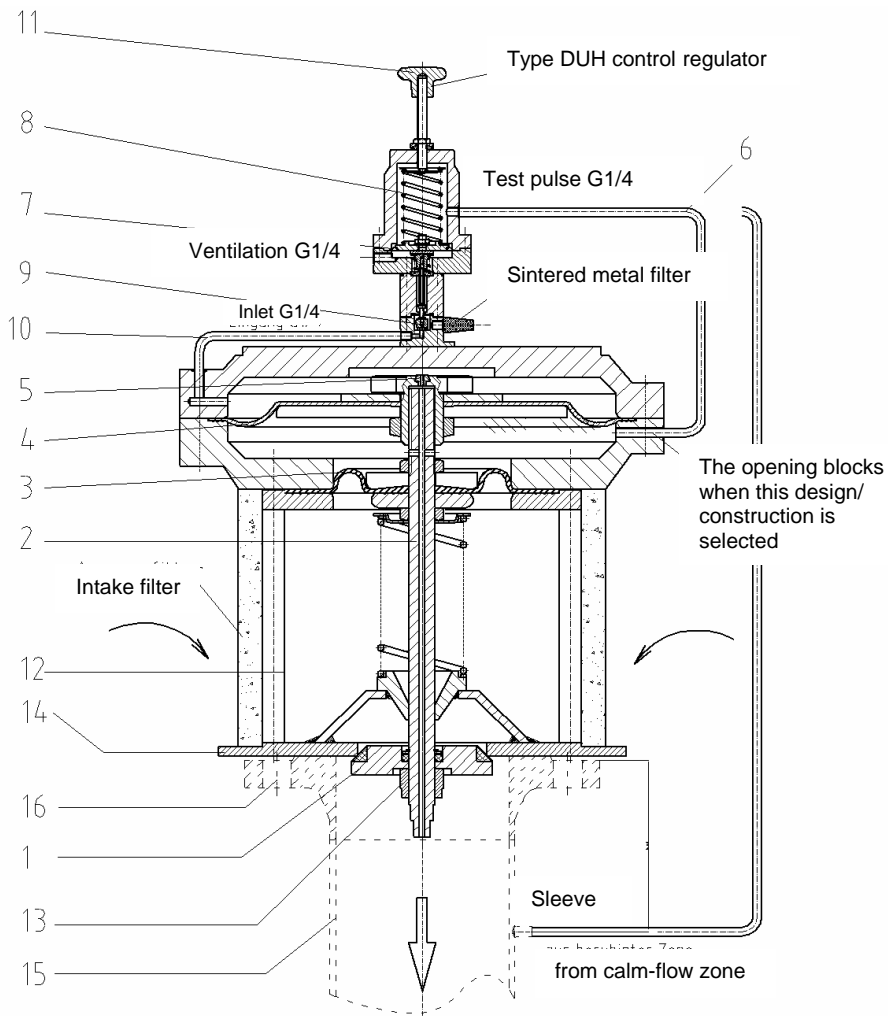

## Type DUH control regulator construction

## Special maintenance instructions

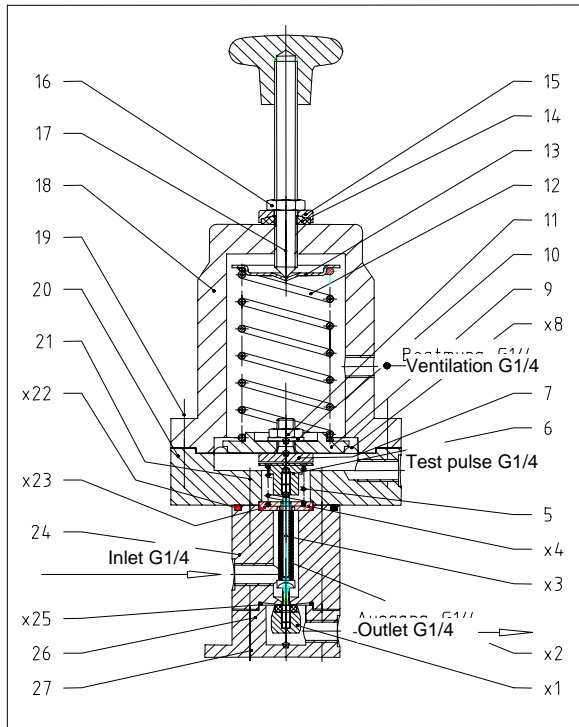

**Illustration 1.2**

x: Keep consumables or parts subject to wear in stock  
Item (2; 3; 4) only supplied complete

### Type DUH control regulator

The control regulator must be disassembled from the main device for maintenance purposes.

Prior to every disassembly of the control regulator it is essential to relieve the tension on the set-point spring 12 with the aid of the cross handle 17.

During maintenance the diaphragm 8, the control regulator element (2, 3, 4) and the control valve 1 must be specially checked for wear.

By loosening the screws 19 the diaphragm 8 can be removed with the suspension 7 and inspected.

When the spring cap 6 is unscrewed and screws 21 and 27 removed, the control valve 1 can be screwed out of the control regulator insert (2, 3, 4), the element removed and examined. The element should be replaced every 5 years at the latest to ensure general operating safety.

When assembling ensure that:

- The control valve 1 is screwed in up to approx. ¼ turn in front of the stop on the control regulator element (2, 3, 4).
- The spring cap 6 is screwed onto the control regulator element (2, 3, 4) only to the point that the control valve 1 lifts approx. 2 mm from the seat of the regulator body 24 when the spring cap 6 is pushed down.

Item	Quantity	Unit	Description	Standard / drawing number	Material / Comment
x1	1	Piece	Control valve	4-St-1/U//a	Ms
x2	1	Piece	Spring body	4-St-2	Bronze
x3	1	Piece	Valve suspension	4-St-3/U	VA
x4	1	Piece	Brazing flange	4-St-4	VA
5	1	Piece	Closing spring	4-St-5	VA spring steel
6	1	Piece	Spring cap	4-St-6	VA
7	1	Piece	Diaphragm suspension	4-St-7	VA
x8	1	Piece	Diaphragm	4-St-8/...	Perbunan
9	1	Piece	Diaphragm plate	4-St-9/...	Al
10	1	Piece	Washer	DIN 125; 10.5x2.5; Form B	St, galvanised
11	1	Piece	Hexagonal nut	DIN 439; M10;	St, galvanised
12	1	Piece	Set-point spring	4-St-12/...	Spring steel C, chromatic
13	1	Piece	Spring plate	4-St-13	ST, chromatic
14	1	Piece	Spindle seal	4-St-14	Perbunan
15	1	Piece	Pressing ring	4-St-15	Ms
16	1	Piece	Hexagonal nut	DIN 431; G1/4;	St, galvanised
17	1	Piece	Cross handle with spindle	4-St-17	Ms; Duroplast
18	1	Piece	Top diaphragm casing	4-St-18/...	Al
19	8	Piece	Allen key screw	DIN 912; M6x20;	8.8, galvanised
20	1	Piece	Bottom diaphragm casing	4-St-20/...	Al
21	4	Piece	Allen key screw	DIN 912; M6x25;	8.8, galvanised
x22	1	Piece	O-ring	48 x 4	Perbunan
x23	1	Piece	O-ring	26 x 2	Perbunan
24	1	Piece	Regulator body	4-St-24/U	Al
x25	1	Piece	O-ring	26 x 2	Perbunan
26	1	Piece	Regulator base	4-St-26/U//a	Al



# REGLER + ARMATUREN

TERSCHÜREN GmbH

27	4	Piece	Allen key screw	DIN 912; M6x50; 8.8	8.8, galvanised
----	---	-------	-----------------	---------------------	-----------------

**Parts list 1.2**