

REGLER + ARMATUREN

Terschüren GmbH

**R
+
A**



**Gas Pressure Regulator
Type 132**

Gas Pressure Regulator Type 132

Scope of Application

Scope of type 132 gas pressure regulator is to maintain the output pressure at a constant level regardless of interferences such as changing input pressure and/or flow rate. It can be used for all gases according to DVGW worksheet G260 and all non-aggressive gases (Special design is available for aggressive gases, particularly gases from dumps or sewage processing plants).

Characteristics

- Connections according to customer requirements (including ANSI and special flanges)
- Large inlet pressure range
- Optional with integrated soundproofing (attenuation approx. 10-20 dB)
- Also available as differential and zero pressure regulator
- Overall length adaptable according to local requirements
- High regulating accuracy, short actuating time
- Easy maintenance; on-site-maintenance possible without removing unit
- Single ply design => few parts subject to wear
- Special version with operating temp. up to 250°C
- Pressure compensated valve combination
- Short outlet path required
- Also as combination with safety shut-off valve type 53N/H
- Extremely low required minimum pressure difference (Pe-Pa)
- No special tools required

DIN-DVGW Registration Numbers

Nominal width	Pressure stage	Registration No.
DN 50	PN 25	94.01c713
DN 80	PN 25	94.02c713
DN 100	PN 16	94.03c713
DN 150	PN 16	94.04c713
DN 200	PN 16	94.05c713
DN 250	PN 16	94.06c713
DN 300	PN 10	94.07c713
DN 350	PN 10	94.08c713
DN 400	PN 10	94.09c713
DN 500	PN 10	94.10c713

Approved according to DIN 3380 "Gas Pressure Regulation Equipment for Input Pressures up to 100 Bar".

Technical Data

Input pressure	up to 25 bar
Output pressure	up to 16 bar
Min. press. Difference	100 mbar 20 mbar* ¹ / 3 mbar* ²
Nominal widths	DN 50; DN 65; DN 80; DN100; DN125; DN150; DN200; DN250; DN300; DN350; DN400; DN500
Type of connection	DIN flanges; ANSI flanges; Special flanges
Valve diameter	50 mm to 500 mm
Operating temperature	-15°C to +60°C* ³
Medium	suitable for all gases according to DVGW worksheet G260 and all non-aggressive gases
Materials	
Body	St 37.0 / St 35.8
Diaphragm housing	GGG 40 / St 37-2
Control regulator	Al
Control press. Reducer	Al
Inner parts	Al, VA, Ms, Steel
Diaphragms, O-rings	Perbunan, Viton
Cone valve	Perbunan, Viton

*¹ : With larger diaphragm housing

*² : Version controlled by external pressure

*³ : Special version up to 250 °C

Adjustment Ranges

Guide range [bar]	Drawing number	RG	SG
Control Regulator DN			
0,01 - 0,12	4-St-12/DN/4	10/5	20/10
0,12 - 0,30	4-St-12/DN/5	5	10
0,30 - 0,60	4-St-12/DN/6	2,5	5
0,60 - 0,75	4-St-12/DN/7	2,5	5
0,75 - 1,00	4-St-12/DN/8	1	2,5
Control Regulator DH			
0,05 - 0,30	4-St-12/DH/4	5	10
0,30 - 1,00	4-St-12/DH/5	5	10
1,00 - 1,90	4-St-12/DH/6	5	10
1,90 - 2,90	4-St-12/DH/7	2,5	5
2,90 - 4,30	4-St-12/DH/8	2,5	5
4,30 - 7,50	4-St-12/DH/9	2,5	5

Other adjustment pressures available on request.

Installation Dimensions

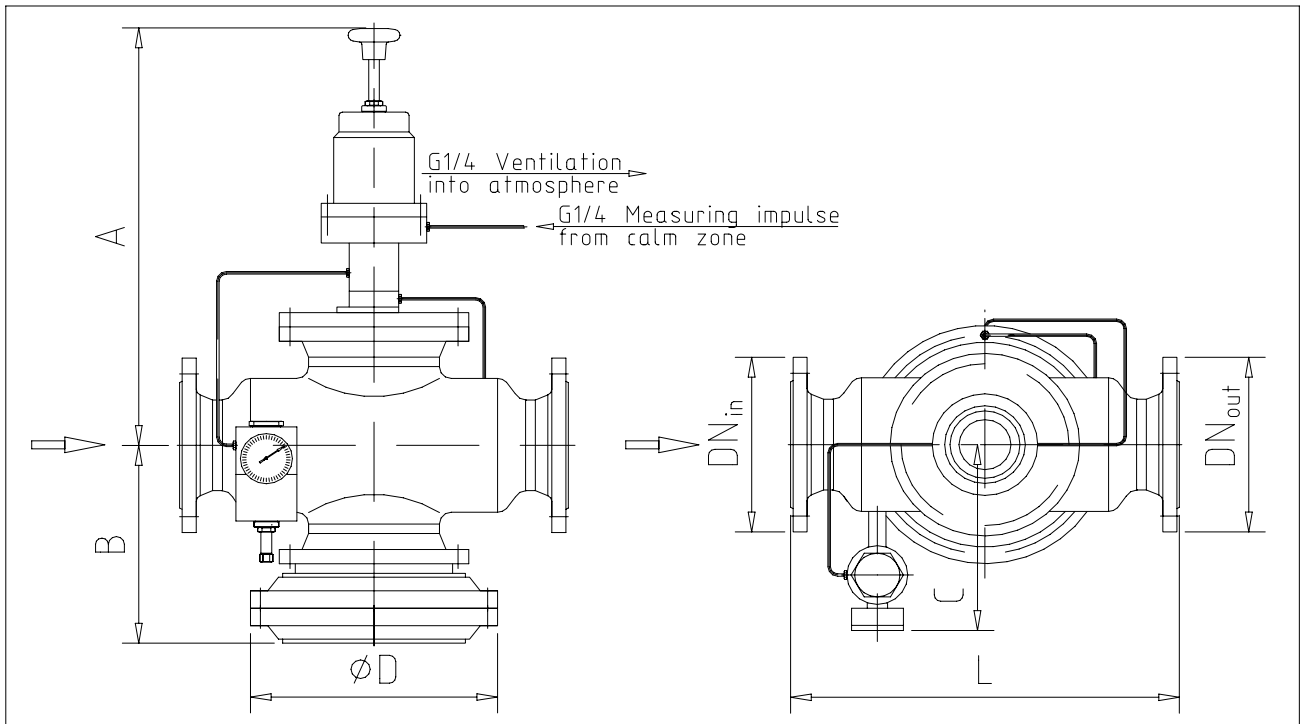

Outlet *1 DN_{out}	Inlet *1 DN_{in}	Valve- ϕ [mm]	L *2 [mm]	A [mm]	B [mm]	D			Weight [kg]
						$\Delta p \geq 1.5 \text{ ba}$ [mm]	$\Delta p \geq 100 \text{ mbar}$ [mm]	$\Delta p \leq 100 \text{ mbar}$ [mm]	
50-150	50-150	50-80	450	570	250	235	300	420	65
		100	450	570	265	235	420	482	80
		125	700	620	320	290	420	482	120
		150	800	660	350	320	420	482	150
200	50-200	50-80	500	590	275	260	300	420	75
		100	500	590	290	260	420	482	95
		125	700	620	320	290	420	482	125
		150	800	650	350	320	420	482	160
250	50-250	200	800	660	400	320	482	585	185
		50-80	800	620	300	290	300	420	110
		100-125	800	620	320	290	420	482	120
		150	900	660	350	320	420	482	150
300	50-300	200	900	660	400	320	482	585	200
		50-80	900	650	330	320	300	420	150
		100-150	900	650	350	320	420	482	170
		200	900	660	400	320	482	585	230

Other dimensions and valve sizes available on request!

*1 : Units available with all flanges according to customer requirements

*2 : Units available with other overall lengths

Line Connections

Ventilation	G1/4	} for unsoldered, threaded pipe fitting with cutting ring according to DIN 2353 for pipe dia. 12x1.5 mm
Measuring pulse	G1/4	
Sockets	G1/4	

Standard Version

Flow direction	left-right
Ventilation	in flow direction right
Measuring pulse	in flow direction right

The flow direction and/or line connections can be changed on customer request.

Installation

Type 132 gas pressure regulator can be installed vertically or horizontally in flow direction. When installed vertically it is necessary to mount the control regulator vertical beneath the control gear. Due to the specific design the test pulse can be installed behind the gas pressure regulator at an distance of 2-3 x DN outlet (5 x DN_{outlet} = better regulation group than specified).

Design and Function of Type 132 Gas Pressure Regulator

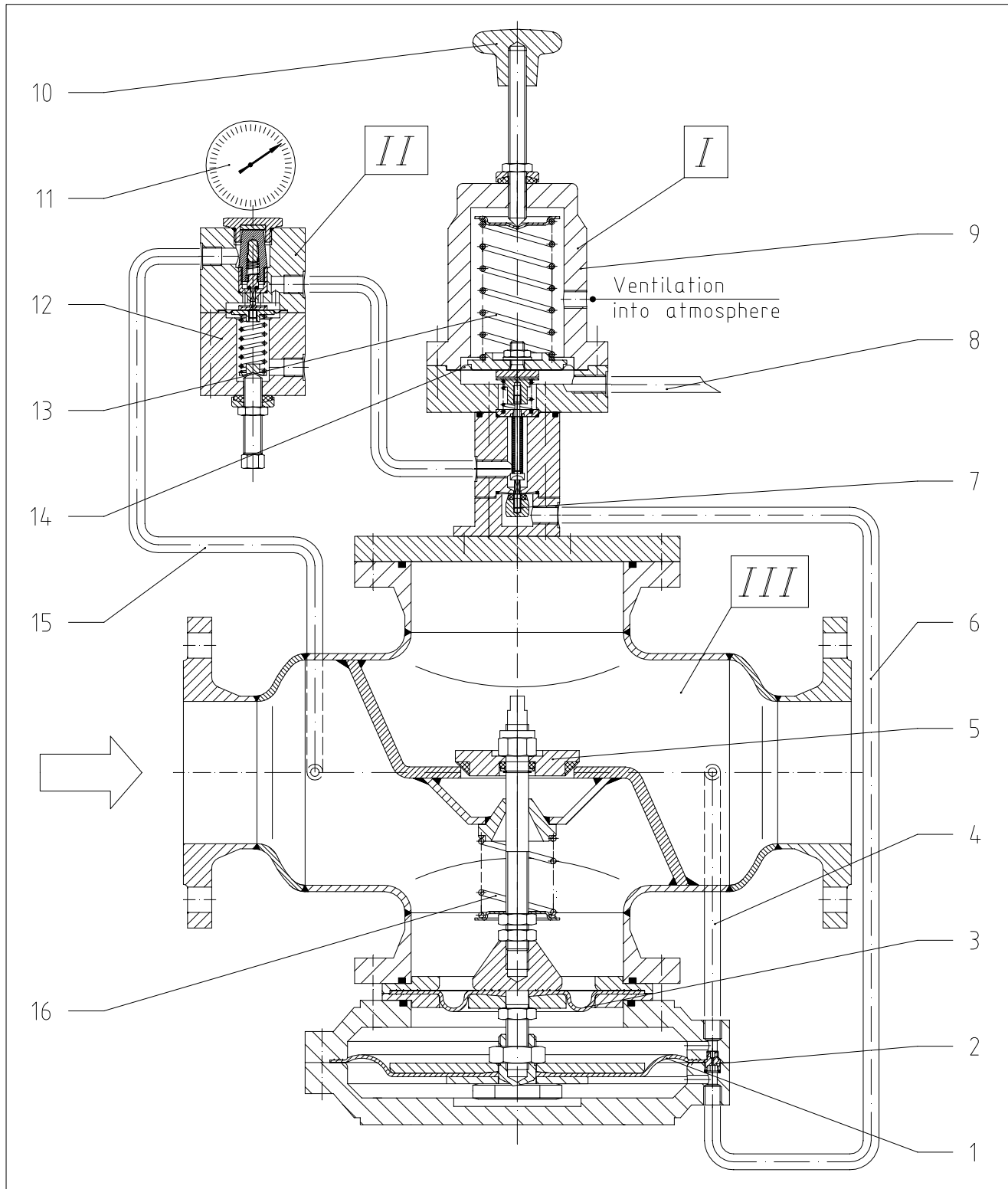

Design

The type 132 gas pressure regulator is composed of three assemblies: control regulator (I), pressure reducer (II) and control gear (III).

The control regulator is available in **DN** and **DH** versions; **DN** is used on a standard basis for pressure range up to 50 mbar, **DH** for operating pressures greater than 50 mbar.

The **SR** pressure reducer is used at a differential pressure of $\Delta p > 1.5$ bar.

Function

Inlet pressure (p_e) flows between cone valve **5** and compensation diaphragm **3**. The cone valve remains closed - even when the inlet pressure varies. Inlet pressure even reaches through control pressure line **15** pressure reducer **12** (with integrated microfilter), which limits the control pressure (application only for $\Delta p > 1.5$ bar). It will be adjusted to the most favourable control characteristic between 0.2 and 1.0 bar above the outlet pressure (p_a). Pressure gauge **11** serves for checking. The reduced pressure reaches control regulator **9**. Control valve **7** is opened by tensioning spring **13** with the cross handle **10** - turning to the right increases outlet pressure. The control pressure reaches through control pressure line **6** into the diaphragm chamber where it acts on the operating diaphragm **1**. The operating diaphragm lifts opening cone valve **5**. The resulting outlet pressure (p_a) reaches through pulse line **8** below control regulator diaphragm **14** lifting it when the set spring value is reached. This closes control valve **7**. The control pressure is equalized to the output pressure via control nozzle **2** and exhaust line **4** and the cone valve **5** closes. The gas pressure regulator is in regulating position.

Starting apparatus

After properly installing the regulator and connecting the pulse lines proceed as follows for start up:

- Release tension of adjustment spring in control regulator (and if necessary in control regulator pressure reducer).
- Slowly open inlet shut off valve; the outlet pressure should not increase.
- If necessary adjust control pressure on pressure reducer (approx. 0.2 bar to 1.0 bar above setting for outlet pressure).
- Slowly tension adjustment spring of control regulator until desired outlet pressure is reached.
- Slowly open outlet shut off valve and adjust to exact outlet pressure.

The gas pressure regulator is ready for operation.

Unit Layout

The **valve flow coefficient K_G** is the value of the flow rate q through gas pressure regulating equipment with control gear completely opened while $p_e = 2.013$ bar abs. and $p_a = 1.013$ bar abs.; measured under standard conditions on a test bench with air as flow medium.

Valve flow coefficient K_G for gas pressure regulator type 132 (converted to natural gas H)

Valve-Ø [mm]	K_G - value [Nm ³ /h]	Valve-Ø [mm]	K_G - value [Nm ³ /h]
50	2.200	150	20.000
65	3.700	175	27.000
80	5.700	200	36.000
100	8.900	250	57.000
125	13.700	300	81.000

Values for larger valve diameters available on request.

The following equations enable to calculate the required K_G value (for $T < 60^\circ\text{C}$):

$$K_G \text{ - value at subcritical pressure ratio}$$

$$\frac{p_a}{p_e} \geq 0,53 : K_G = \frac{q_n}{\sqrt{p_a(p_e - p_a)}} \quad [\text{Nm}^3/\text{h}]$$

(q_n in [Nm³/h]; p_e and p_a in [bar abs.])

$$K_G \text{ - value at supercritical pressure ratio}$$

$$\frac{p_a}{p_e} < 0,53 : K_G = \frac{q_n \cdot 2}{p_e} \quad [\text{Nm}^3/\text{h}]$$

When other gases are used it is necessary to convert q_n with the following corrective factors f :

Medium	f	Medium	f
Ammonia	1,00	Methane	1,04
Butane	0,53	Town gas	1,18
CO ₂	0,62	Oxygen	0,72
Nat. gas L	0,97	Nitrogen	0,78
Air	0,77	Hydrogen	3,02

Values for other mediums available on request.

$$\text{Conversion equation: } q_n = \frac{q_{n\text{Medium}}}{f} \quad [\text{Nm}^3/\text{h}]$$

Calculation of **nominal connection width**:

$$D_{\min} = \sqrt{\frac{q_n \cdot 1,3 \cdot (273 + T)}{p \cdot v_{\max}}} \quad [\text{mm}]$$

q_n : [Nm³/h]; p : [bar abs.]; v_{\max} : [m/s]; T : [°C]
 v_{\max} = max. permissible flow velocity

Optimum valve diameter and nominal connection width can be calculated for each medium and unit with a computer program in our office.

External Pressure Control

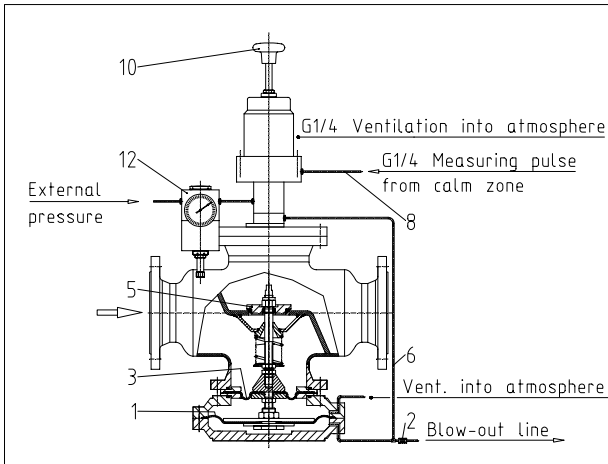

Gas pressure regulators with external pressure control are used primarily when the pressure difference between p_e and p_a is not sufficient to control the regulator (fast enough). Regularly compressed air is used as external medium.

Using external pressure controlled units it must be considered that a small quantity of the external pressure medium is consumed continuously (5-30 l/min depending on control pressure).

Control function corresponds to the function described on page 5. When used with aggressive mediums ventilate piping to free atmosphere is to install.

Diaphragm Housing On Top

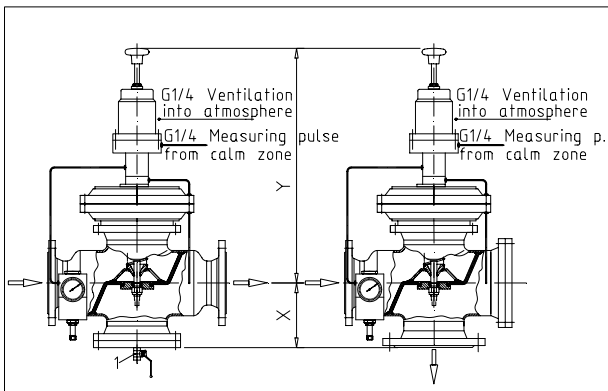

Units with diaphragm housings on top are preferred in two cases:

- a) When large quantities of condensate are expected, which would assemble on the diaphragms (for example with extremely moist gases). In such cases an additional condensate drain cock 1 can be installed.
- b) When an extremely short overall length with outlet downward is required (for example in cabinet systems).

Control function corresponds to the function described on page 5. Dimensions x and y available on request.

Primary Soundproofing

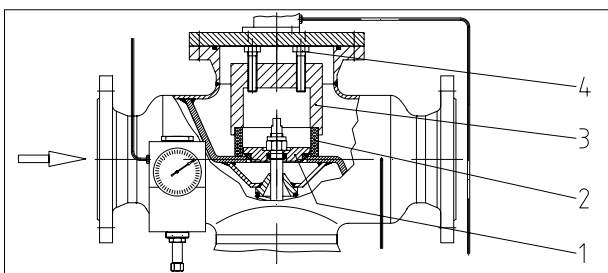

Expanding noises can be reduced approximate 10 - 20 dB with primary soundproofing. Additional installation is possible at any time. In such cases it is necessary that noise damping element 2 is held centered above valve 1 with holder 3. Screw 4 should extend approx. 2-3 mm above the edge of the body flange when installed with the rubber seal to ensure that sufficient pressure is present.

External Control Nozzle

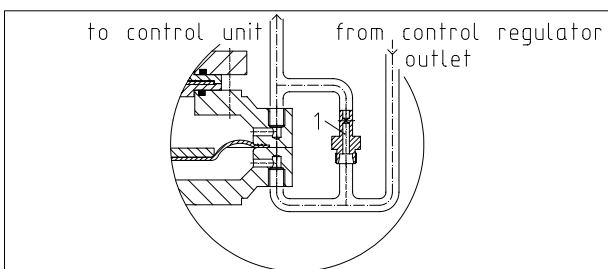

- An external control nozzle can be used
- when contamination and clogging is expected,
- a steel diaphragm housing is used,
- easier and quicker accessibility to the control nozzle is required.

The control nozzle is designed on a standard basis with Ermeto connection 10L.

Motor Control

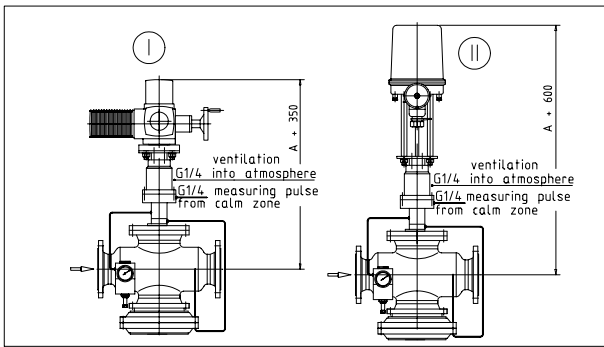

Gas pressure regulators can be equipped with a servo-motor for electrically driven adjustment of output pressure.

The servo-motors are available in two versions:

I: Motor servo-drive, brand AUMA, 380 V AC, also available with design for explosion hazard areas;

II: Motor servo-drive, brand RTK, 230 V AC, also 24 V DC and 380 V AC.

Control function of the gas pressure regulator corresponds to the description on page 5.

Inlet Pressure Protection

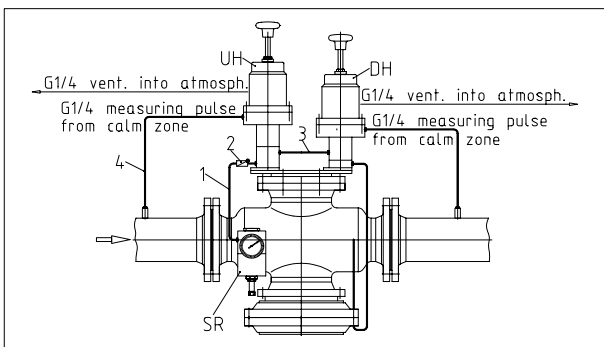

Gas pressure regulators with inlet pressure protection can be used to prevent the pressure regulator from feeding medium to the outlet side when the inlet pressure drops below a certain value. Pressure switch point is to adjust by the control regulator **UH** (turning to right increases value).

When inlet pressure decreases, check valve **2** prevents medium flowing from outlet side through control lines **3-1** into control pressure reducer **SR** (or directly into the inlet pressure) and damaging it.

Differential or Balanced Pressure Control

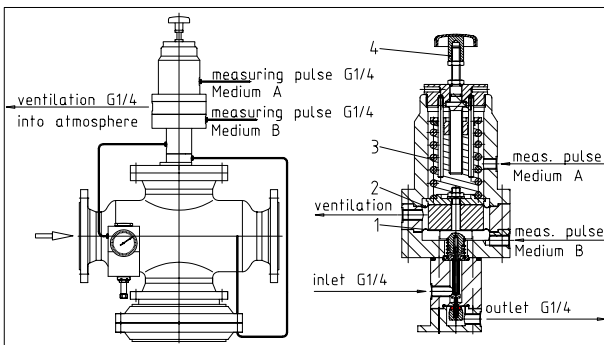

Gas pressure regulators with differential or balanced pressure control are used regulating the pressure of the main medium in relation to the pressure of a second medium.

To prevent mixing of the two **media A** and **B** in the event of a diaphragm crack in the control regulator they are separated by two diaphragms **1** and **2**.

Requested differential or balanced pressure can be adjusted by cross handle **4** (turn right to increase value).

Two Operating Pressures

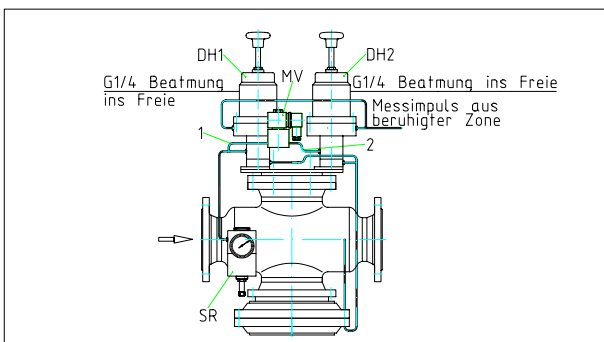

By combining two control regulators and a solenoid valve it is possible to regulate two different outlet pressures (applications) with one gas pressure regulator.

The **DH1** control regulator is positioned to the lower pressure p_{a1} ; it is always in operation. By opening solenoid valve **MV** the second control regulator **DH2** is activated and regulates the high pressure p_{a2} .

At pressure differences of $p_{a2} - p_{a1} > 1$ bar two control pressure reducers **SR** are required.

Design Type 132 Control Unit

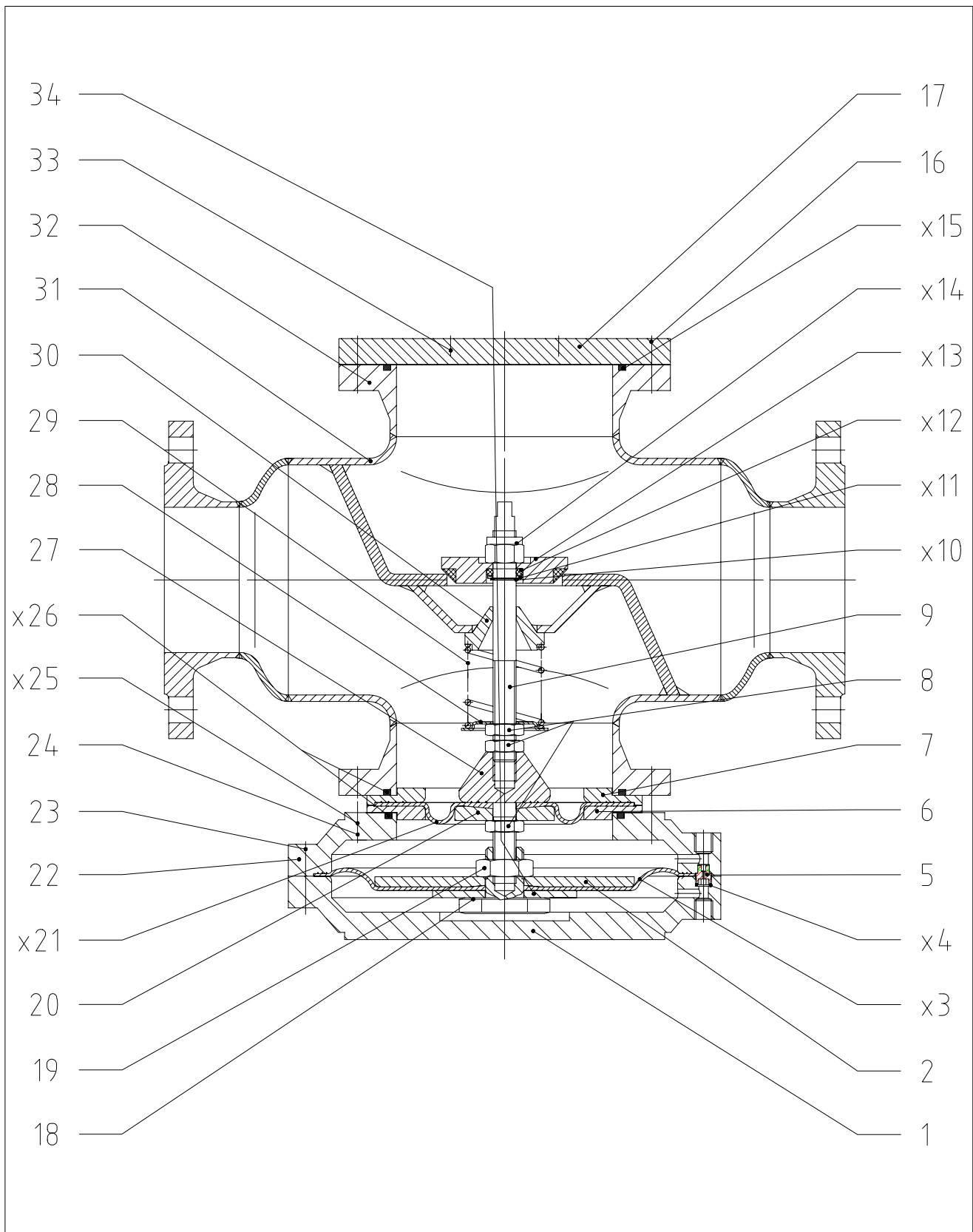

x: Parts subject to wear; keep on hand for maintenance

Components for Type 132 Control Unit

Item	Quant.	Units	Designation	Standard / drawing No.	Material / remarks
1	1	Piece	Bottom diaphragm housing	4-132-1/...	GGG 40 / St
2	1	Piece	Diaphragm plate, operat. diaphr.	4-132-2/...	St, chromatic
x3	1	Piece	Operating diaphragm	4-132-3/...	Perbunan
x4	1	Piece	Control nozzle gasket	8 x 12 x 6	Perbunan
5	1	Piece	Control nozzle	4-132-5	VA
6	1	Piece	Bottom diaphragm ring	4-132-6/...	St, chromatic
7	1	Piece	Upper diaphragm ring	4-132-7/...	St, chromatic
x8	3	Piec	Hex. nut	DIN 439, M16	St, galvanized
9	1	Piece	Valve suspension	4-132-9/...	VA
x10	1	Piece	Circlip	DIN 471, 16 x 1	Spring steel, galv.
x11	2	Piece	Sealing ring	DIN 7603 A, 16 x 24 x 1.5	Cu
x12	1	Piece	O-ring	16 x 5	Perbunan
x13	1	Piece	Cone valve	4-132-13/...	Al, Perbunan
x14	1	Piece	Retaining nut	DIN 982, M16	St, galvanized
x15	1	Piece	Round cord seal	∅ 5	Perbunan
16	8/12	Piece	Allen screw	DIN 912, M12 x 20 / 30	8.8, galvanized
17	1	Piece	Blind flange	4-132-17/...	St, chromatic
18	1	Piece	Operating diaphragm suspension	4-132-18/...	Al
19	1	Piece	Hex. nut	DIN 431, G3/4	St, galvanized
20	1	Piece	Diaphragm plate	4-132-20/...	Al
x21	1	Piece	Compensation diaphragm	4-132-21/...	Perbunan
22	1	Piece	Upper diaphragm housing	4-132-22/...	GGG 40 / St
23	16	Piece	Allen screw	DIN 912, M10 x 30	8.8, galvanized
24	8	Piece	Allen screw	DIN 912, M12 x 45	8.8, galvanized
x25	8	Piece	Sealing ring	DIN 7603, 12 x 18 x 1.5	Cu
x26	2	Piece	Round cord seal	∅ 5	Perbunan
27	1	Piece	Compensat. diaphr. suspension	4-132-27	Al
28	1	Piece	Spring plate	4-132-28	St, chromatic
29	1	Piece	Closing spring	4-132-29	Spring steel C, chrom.
30	1	Piece	Valve guide	4-132-30	St
31	1	Piece	Body	4-132-31/...	St
32	2	Piece	Body flange	4-132-32/...	St
33	2	Piece	Allen screw	DIN 912, M8 X 15	8.8, galvanized
34	1	Piece	Diaphragm plate	4-132-34	St, chromatic

Special Maintenance Instructions

Type 132 Control Unit

Waiting control unit check cone valve **13** connection for leakage and diaphragms **3** and **21** for wear and solidity.

To check cone valve **13** for leakage first release tension of adjustment spring of control regulator and close the shut off valve behind the gas pressure regulator. The pressure behind gas pressure regulator should no longer increase.

To remove cone valve **13** first detach screws **16** and remove blind flange **17**. Then loosen self-locking nut **14** while holding valve suspension **9** with another wrench (important).

When installing ensure that items **10**, **11**, **12**, **14** and **15** are also replaced.

In order to check operating diaphragm **3** first loosen screws **23** and remove the bottom diaphragm housing **1**. After that operating diaphragm **3** can be screwed out together with diaphragm suspension **18** and checked. After loosening screws **24** upper diaphragm housing **22** can be removed and the compensating diaphragm **21** screwed out together with diaphragm suspension **27** and checked; during this operation hold middle hex. nut **8** with a wrench. When installing ensure that items **4**, **25** and **26** are also replaced.

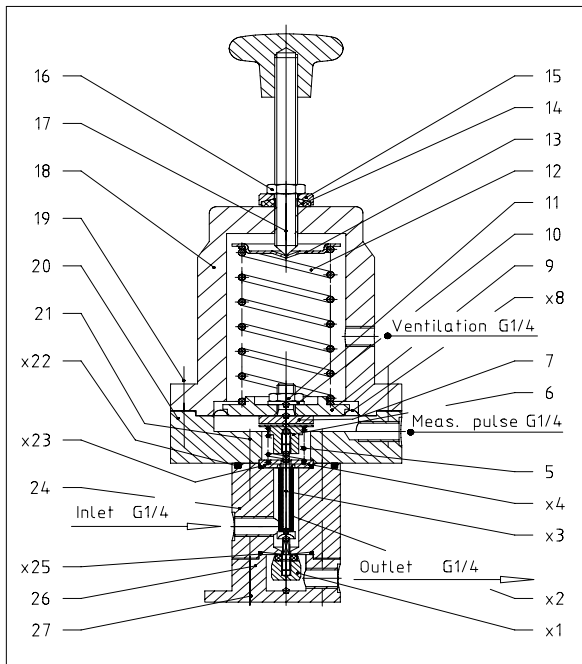
Design Type DH, DN Control Regulator

x: Parts subject to wear; keep on hand for maintenance
Items (2; 3; 4) only available complete

Special Maintenance Instructions**Type DH, DN control regulator**

It is necessary to remove type DH and DN control regulators from the main unit for maintenance purposes. Before disassembling the control regulator always release the tension on the adjustment spring **12** with cross handle **17**. During maintenance check diaphragm **8**, the control regulator insert (**2, 3, 4**) and control valve **1** especially for wear. Diaphragm **8** can be removed together with suspension **7** and checked after loosening screws **19**. When the spring cap **6** is unscrewed and screws **21** and **27** removed control valve can be screwed out of the control regulator insert (**2, 3, 4**), the insert removed and checked. The insert should be replaced every **5** years at the latest to ensure general operating safety.

When assembling ensure that:

- control valve **1** is screwed in up to approx. $\frac{1}{4}$ turn in front of the stop on the control regulator insert (**2-4**).
- spring cap **6** is screwed on to the control regulator insert (**2-4**) only to the point that control valve **1** lifts approx. 2 mm from the seat of the regulator body **24** when the spring cap **6** is pushed down.

Components for DH, DN Control Regulator

Item	Quant.	Units	Designation	Standard /drawing number	Material / remarks
x1	1	Piece	Control valve	4-St-1/D	Ms
x2	1	Piece	Spring body	4-St-2	Bronze
x3	1	Piece	Valve suspension	4-St-3/D	VA
x4	1	Piece	Brazing flange	4-St-4	VA
5	1	Piece	Closing spring	4-St-5	VA-spring steel
6	1	Piece	Spring cap	4-St-6	VA
7	1	Piece	Diaphragm suspension	4-St-7	VA
x8	1	Piece	Diaphragm	4-St-8/...	Perbunan
9	1	Piece	Diaphragm plate	4-St-9/...	Al
10	1	Piece	Washer	DIN 125; 10.5x2.5; Form B	St, galvanized
11	1	Piece	Hex. nut	DIN 439; M10;	St, galvanized
12	1	Piece	Adjustment spring	4-St-12/...	Spring steel C,chromat.
13	1	Piece	Spring plate	4-St-13	St, chromatic
14	1	Piece	Spindle seal	4-St-14	Perbunan
15	1	Piece	Pressing ring	4-St-15	Ms
16	1	Piece	Hex. nut	DIN 431; G1/4;	St, galvanized
17	1	Piece	Cross handle with spindle	4-St-17	Ms; Duroplast
18	1	Piece	Upper diaphragm housing	4-St-18/...	Al
19	8	Piece	Allen screw	DIN 912; M6x20;	8.8, galvanized
20	1	Piece	Bottom diaphragm housing	4-St-20/...	Al
21	4	Piece	Allen screw	DIN 912; M6x25;	8.8, galvanized
x22	1	Piece	O-ring	48 x 4	Perbunan
x23	1	Piece	O-ring	26 x 2	Perbunan
24	1	Piece	Regulator body	4-St-24/D	Al
x25	1	Piece	O-ring	26 x 2	Perbunan
26	1	Piece	Regulator base	4-St-26/D	Al
27	4	Piece	Allen screw	DIN 912; M6x50; 8.8	8.8, galvanized

Design Type SR Pressure Reducer

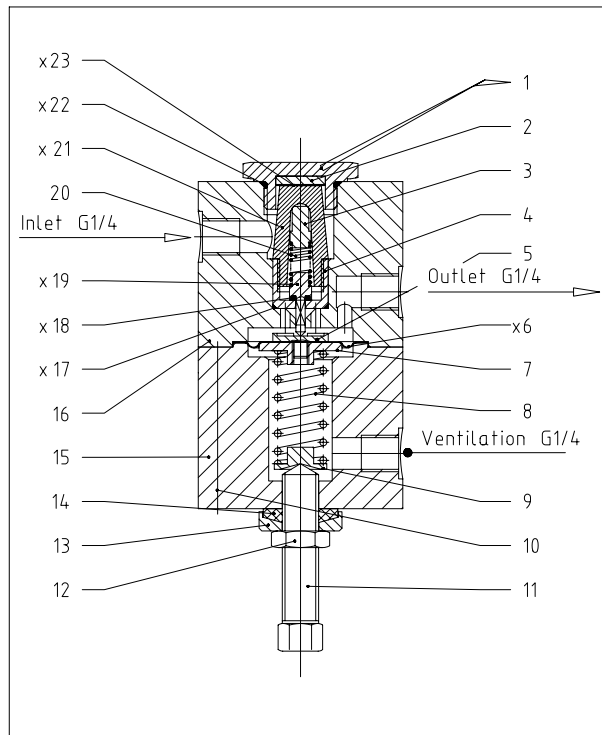

x: Parts subject to wear; keep on hand for maintenance
Items (18, 19) only available complete

Special Maintenance Instructions

Type SR pressure reducer

Type SR pressure reducer with integrated sinter metal filter can be disassembled for maintenance works. For this purpose unscrew Ermeto fittings on the inlet and outlet. The unit can be checked for proper function on a test bench when removed.

Before disassembling the pressure reducer always release the pressure on adjustment spring **8** with spindle **11**.

When servicing check especially diaphragm **6** for wear and filter element **21** for clogging.

After loosening allen screws **10** top valve element **15** can be taken off and diaphragm suspension **5** and diaphragm plate **7** and checked.

After loosening plug **1** filter element **21** can be removed together with valve insert **4**. If the filter element no longer has a yellow/gold shimmer, replace it. The filter element should be changed every two year at the latest to ensure general operating reliability.

Components for Type SR Pressure Reducer

Item	Quant.	Units	Designation	Standard / drawing number	Material / remarks
1	1	Piece	Plug	4-SR-1	Ms
2	1	Piece	Compensation plate	18.5 x 6	Sponge rubber
3	1	Piece	Spring pressure element	4-SR-3	VA
4	1	Piece	Valve insert	4-SR-4	Ms
5	1	Piece	Diaphragm suspension	4-SR-5	St, chromatic
x6	1	Piece	Diaphragm	4-SR-6	Perbunan
7	1	Piece	Diaphragm plate	4-SR-7	Al
8	1	Piece	Adjustment spring	4-SR-8/...	Spring steel C, chromat.
9	1	Piece	Spring plate	4-SR-9/...	St, chromatic
10	4	Piece	Allen screw	DIN 912; M6 x 65	8.8, galvanized
11	1	Piece	Spindle	4-SR-11	Ms
12	1	Piece	Hex. nut	DIN 431; G1/4	St, galvanized
13	1	Piece	Pressing ring	4-St-15	Ms
14	1	Piece	Spindle seal	4-St-14	Perbunan
15	1	Piece	Upper valve element	4-SR-15	Al
16	1	Piece	Bottom valve element	4-SR-16	Al
x17	1	Piece	O-ring	17 x 1.5	Perbunan
x18	1	Piece	O-ring	2.9 x 1.78	Perbunan
x19	1	Piece	Control valve	4-SR-19	Ms
20	1	Piece	Closing spring	4-SR-20	VA-spring steel
x21	1	Piece	Filter element	4-SR-21	Sinter bronze
x22	1	Piece	O-ring	22 x 3	Perbunan
x23	1	Piece	Gasket	18.5 x 0.4	PTFE